

SECTION **CHG**
CHARGING SYSTEM

A
B
C
D
E
F
G
H
I
J
K
L

CONTENTS

BASIC INSPECTION	2	S TERMINAL CIRCUIT	17
DIAGNOSIS AND REPAIR WORKFLOW	2	Description	17
Work Flow (With EXP-800 NI or GR8-1200 NI)	2	Diagnosis Procedure	17
Work Flow (Without EXP-800 NI or GR8-1200 NI).....	5	WIRING DIAGRAM	18
SYSTEM DESCRIPTION	8	CHARGING SYSTEM	18
CHARGING SYSTEM	8	Wiring Diagram	18
System Diagram	8	SYMPTOM DIAGNOSIS	25
System Description	8	CHARGING SYSTEM	25
Component Description	8	Symptom Table	25
POWER GENERATION VOLTAGE VARIABLE CONTROL SYSTEM	9	PRECAUTION	26
System Diagram	9	PRECAUTIONS	26
System Description	9	Precaution for Supplemental Restraint System (SRS) "AIR BAG" and "SEAT BELT PRE-TENSIONER"	26
Component Description	9	Precaution for Power Generation Voltage Variable Control System	26
DTC/CIRCUIT DIAGNOSIS	10	PREPARATION	27
CHARGING SYSTEM PRELIMINARY INSPECTION	10	PREPARATION	27
Diagnosis Procedure	10	Special Service Tool	27
POWER GENERATION VOLTAGE VARIABLE CONTROL SYSTEM OPERATION INSPECTION	11	Commercial Service Tool	27
Diagnosis Procedure	11	REMOVAL AND INSTALLATION	28
B TERMINAL CIRCUIT	13	GENERATOR	28
Description	13	Exploded View	28
Diagnosis Procedure	13	Removal and Installation	28
L TERMINAL CIRCUIT (OPEN)	14	Inspection	29
Description	14	SERVICE DATA AND SPECIFICATIONS (SDS)	30
Diagnosis Procedure	14	SERVICE DATA AND SPECIFICATIONS (SDS)	30
L TERMINAL CIRCUIT (SHORT)	16	Generator	30
Description	16		
Diagnosis Procedure	16		

CHG

N
O
P

DIAGNOSIS AND REPAIR WORKFLOW

< BASIC INSPECTION >

BASIC INSPECTION

DIAGNOSIS AND REPAIR WORKFLOW

Work Flow (With EXP-800 NI or GR8-1200 NI)

INFOID:000000009465962

CHARGING SYSTEM DIAGNOSIS WITH EXP-800 NI OR GR8-1200 NI

To test the charging system, use the following special service tools:

- EXP-800 NI Battery and electrical diagnostic analyzer
- GR8-1200 NI Multitasking battery and electrical diagnostic station

NOTE:

Refer to the applicable Instruction Manual for proper charging system diagnosis procedures.

DIAGNOSIS AND REPAIR WORKFLOW

< BASIC INSPECTION >

OVERALL SEQUENCE

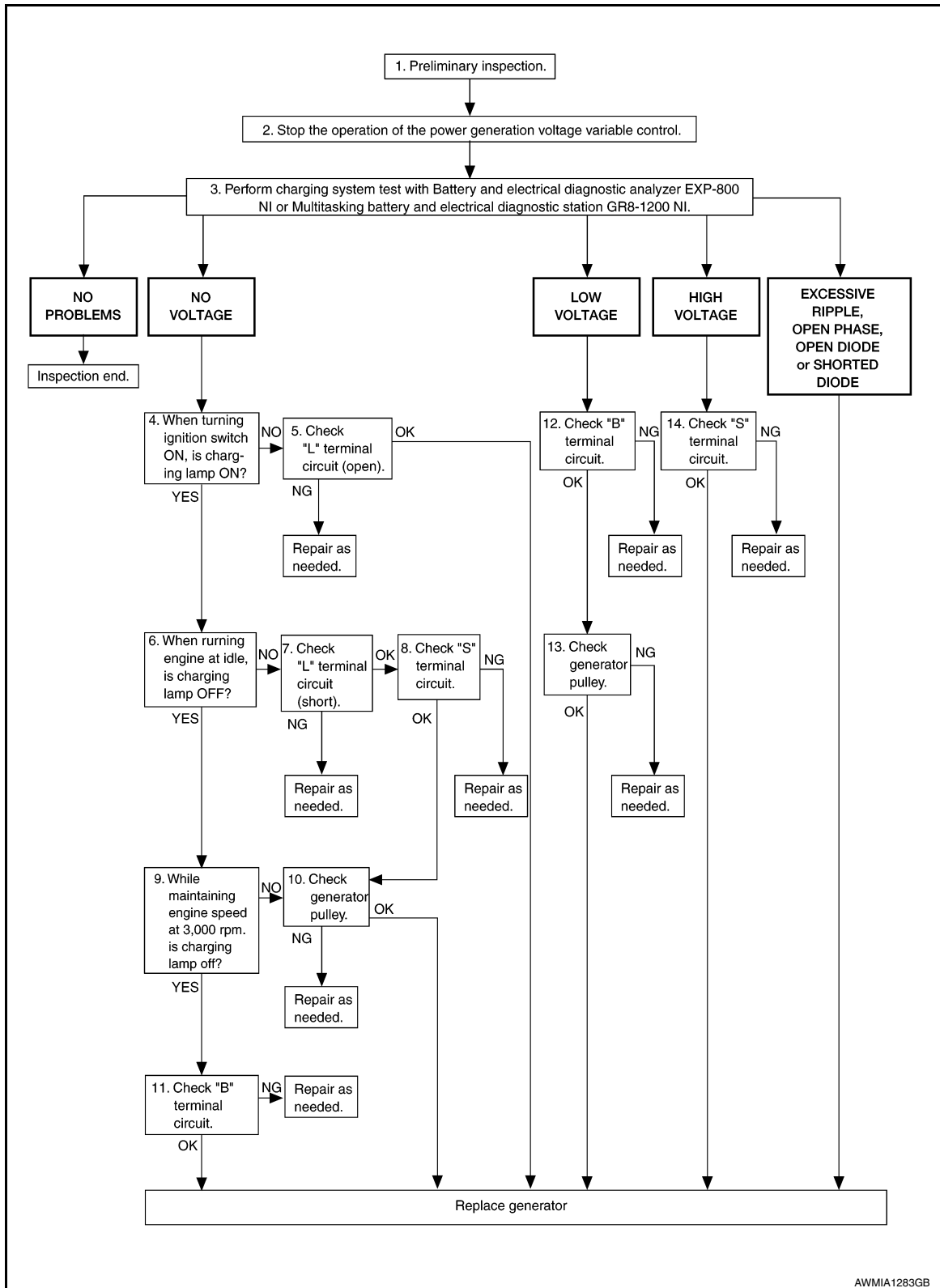

DETAILED FLOW

NOTE:

To ensure a complete and thorough diagnosis, the battery, starter and generator test segments must be done as a set from start to finish.

1. PRELIMINARY INSPECTION

Perform the preliminary inspection. Refer to [CHG-10. "Diagnosis Procedure"](#).

A
B
C
D
E
F
G
H
I
J
K
L
CHG
N
O
P

DIAGNOSIS AND REPAIR WORKFLOW

< BASIC INSPECTION >

>> GO TO 2.

2. STOP POWER GENERATION VOLTAGE VARIABLE CONTROL SYSTEM

Stop the operation of the power generation voltage variable control in either of the following procedures.

- After selecting “ENGINE” using CONSULT, set the DUTY value of “ALTERNATOR DUTY” to 0 % by selecting “ALTERNATOR DUTY” of “Active Test”. Continue “Active Test” until the end of inspection. (When the DUTY value is 0 or 100 %, the normal power generation is performed according to the characteristic of the IC regulator of the generator.)
- Turn the ignition switch OFF, and disconnect the battery current sensor connector. [However, DTC (P1550–P1554) of the engine might remain. After finishing the inspection, connect the battery current sensor connector and erase the self diagnosis results history of the engine using CONSULT.]

>> GO TO 3.

3. DIAGNOSIS WITH EXP-800 NI OR GR8-1200 NI

Perform the charging system test using Multitasking battery and electrical diagnostic station GR8-1200 NI or Battery and electrical diagnostic analyzer EXP-800 NI. Refer to the applicable Instruction Manual for proper testing procedures.

Test result

NO PROBLEMS>>Charging system is normal and will also show “DIODE RIPPLE” test result.

NO VOLTAGE>>GO TO 4.

LOW VOLTAGE>>GO TO 12.

HIGH VOLTAGE>>GO TO 14.

EXCESSIVE RIPPLE, OPEN PHASE, OPEN DIODE or SHORTED DIODE>>Replace the generator. Refer to [CHG-28, "Removal and Installation"](#). Perform “DIODE RIPPLE” test again using Multitasking battery and electrical diagnostic station GR8-1200 NI or Battery and electrical diagnostic analyzer EXP-800 NI to confirm repair.

4. INSPECTION WITH CHARGE WARNING LAMP (IGNITION SWITCH IS ON)

Turn the ignition switch ON.

Does the charge warning lamp illuminate?

YES >> GO TO 6.

NO >> GO TO 5.

5. “L” TERMINAL CIRCUIT (OPEN) INSPECTION

Check “L” terminal circuit (open). Refer to [CHG-14, "Diagnosis Procedure"](#).

Is the “L” terminal circuit normal?

YES >> Replace generator. Refer to [CHG-28, "Removal and Installation"](#).

NO >> Repair as needed.

6. INSPECTION WITH CHARGE WARNING LAMP (IDLING)

Start the engine and run it at idle.

Does the charge warning lamp turn OFF?

YES >> GO TO 9.

NO >> GO TO 7.

7. “L” TERMINAL CIRCUIT (SHORT) INSPECTION

Check “L” terminal circuit (short). Refer to [CHG-16, "Diagnosis Procedure"](#).

Is the “L” terminal circuit normal?

YES >> GO TO 8.

NO >> Repair as needed.

8. “S” TERMINAL CIRCUIT INSPECTION

Check “S” terminal circuit. Refer to [CHG-17, "Diagnosis Procedure"](#).

Is the “S” terminal circuit normal?

YES >> GO TO 10.

DIAGNOSIS AND REPAIR WORKFLOW

< BASIC INSPECTION >

NO >> Repair as needed.

9. INSPECTION WITH CHARGE WARNING LAMP (ENGINE AT 3,000 RPM)

Increase and maintain the engine speed at 3,000 rpm.

Does the charge warning lamp remain off?

YES >> GO TO 11.

NO >> GO TO 10.

10. INSPECTION OF GENERATOR PULLEY

Check generator pulley. Refer to [CHG-28. "Removal and Installation"](#).

Is generator pulley normal?

YES >> Replace generator. Refer to [CHG-28. "Removal and Installation"](#).

NO >> Repair as needed.

11. "B" TERMINAL CIRCUIT INSPECTION

Check "B" terminal circuit. Refer to [CHG-13. "Diagnosis Procedure"](#).

Is "B" terminal circuit normal?

YES >> Replace generator. Refer to [CHG-28. "Removal and Installation"](#).

NO >> Repair as needed.

12. "B" TERMINAL CIRCUIT INSPECTION

Check "B" terminal circuit. Refer to [CHG-13. "Diagnosis Procedure"](#).

Is "B" terminal circuit normal?

YES >> GO TO 13.

NO >> Repair as needed.

13. INSPECTION OF GENERATOR PULLEY

Check generator pulley. Refer to [CHG-28. "Removal and Installation"](#).

Is generator pulley normal?

YES >> Replace generator. Refer to [CHG-28. "Removal and Installation"](#).

NO >> Repair as needed.

14. "S" TERMINAL CIRCUIT INSPECTION

Check "S" terminal circuit. Refer to [CHG-17. "Diagnosis Procedure"](#).

Is the "S" terminal circuit normal?

YES >> Replace generator. Refer to [CHG-28. "Removal and Installation"](#).

NO >> Repair as needed.

Work Flow (Without EXP-800 NI or GR8-1200 NI)

INFOID:000000009465963

OVERALL SEQUENCE

Before performing a generator test, make sure that the battery is fully charged. A 30-volt voltmeter and suitable test probes are necessary for the test.

- Before starting, inspect the fusible link.

A
B
C
D
E
F
G
H
I
J
K
L
N
O
P

CHG

DIAGNOSIS AND REPAIR WORKFLOW

< BASIC INSPECTION >

- Use fully charged battery.

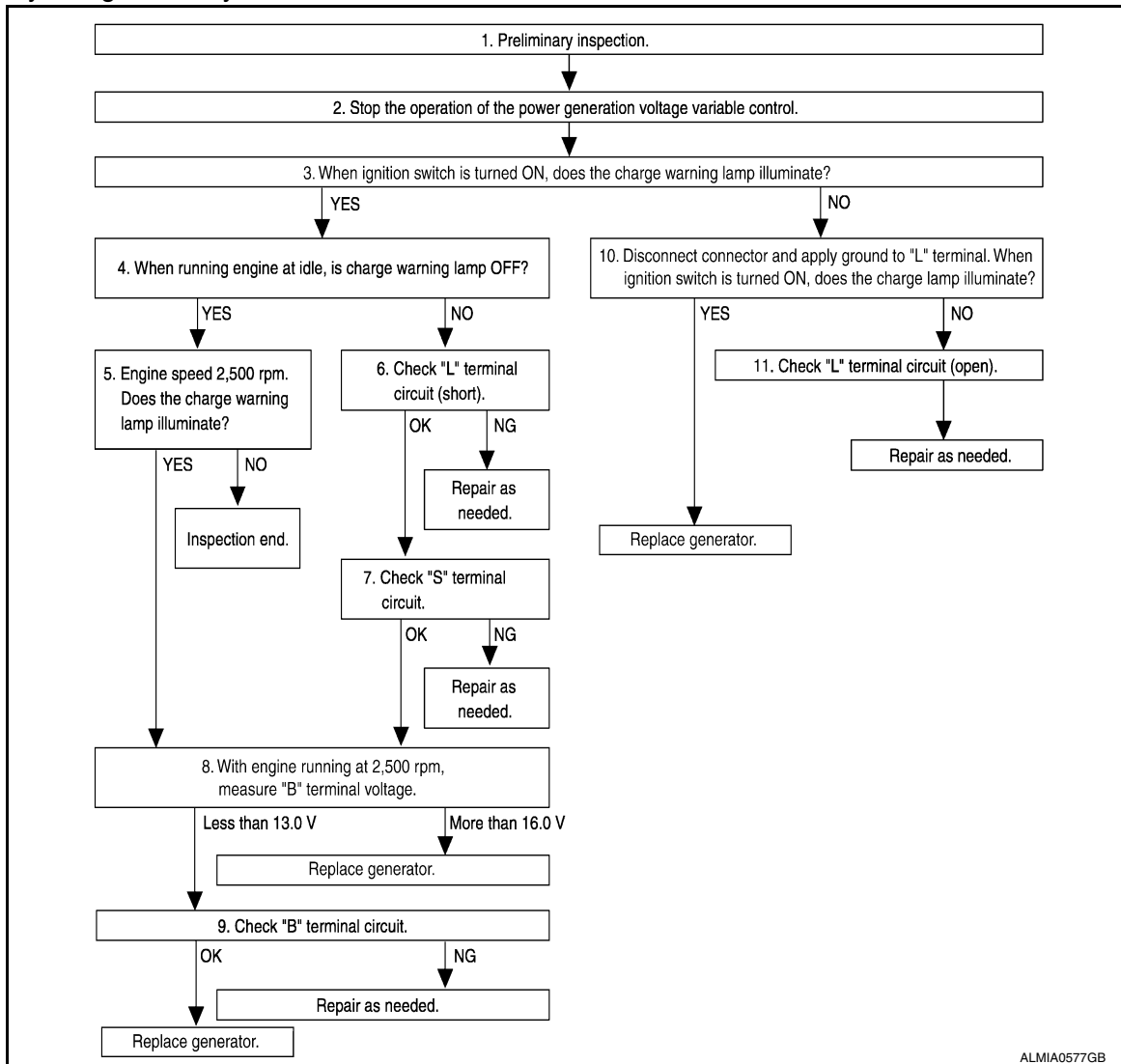

DETAILED FLOW

1. PRELIMINARY INSPECTION

Perform the preliminary inspection. Refer to [CHG-10, "Diagnosis Procedure"](#).

>> GO TO 2.

2. STOP POWER GENERATION VOLTAGE VARIABLE CONTROL SYSTEM

Stop the operation of the power generation voltage variable control in either of the following procedures:

- After selecting "ENGINE" using CONSULT, set the DUTY value of "ALTERNATOR DUTY" to 0 % by selecting "ALTERNATOR DUTY" with "Active Test". Continue "Active Test" until the end of inspection. (When the DUTY value is 0 or 100 %, the normal power generation is performed according to the characteristic of the IC regulator of the generator.)
- Turn the ignition switch OFF, and disconnect the battery current sensor connector. [However, DTC (P1550 - P1554) of the engine might remain. After finishing the inspection, connect the battery current sensor connector and erase the self-diagnostic results history of the engine using CONSULT.]

>> GO TO 3.

3. INSPECTION WITH CHARGE WARNING LAMP (IGNITION SWITCH IS TURNED ON)

When ignition switch is turned ON.

Does the charge warning lamp illuminate?

DIAGNOSIS AND REPAIR WORKFLOW

< BASIC INSPECTION >

YES >> GO TO 4.
NO >> GO TO 10.

4.INSPECTION WITH CHARGE WARNING LAMP (IDLING)

Start the engine and run it at idle

Does the charge warning lamp turn OFF?

YES >> GO TO 5.
NO >> GO TO 6.

5.INSPECTION WITH CHARGE WARNING LAMP (ENGINE AT 2,500 RPM)

Increase and maintain the engine speed at 2,500 rpm.

Does the charge warning lamp illuminate?

YES >> GO TO 8.
NO >> Inspection End.

6.“L” TERMINAL CIRCUIT (SHORT) INSPECTION

Check terminal “L” circuit for (short). Refer to [CHG-16, "Diagnosis Procedure"](#).

Is the inspection result normal?

YES >> GO TO 7.
NO >> Repair as needed.

7.“S” TERMINAL CIRCUIT INSPECTION

Check terminal “S” circuit. Refer to [CHG-17, "Diagnosis Procedure"](#).

Is the inspection result normal?

YES >> GO TO 8.
NO >> Repair as needed.

8.MEASURE “B” TERMINAL VOLTAGE

Start engine. With engine running at 2,500 rpm, measure “B” terminal voltage.

What voltage does the measurement result show?

Less than 13.0 V>>GO TO 9.
More than 16.0 V>>Replace generator. Refer to [CHG-28, "Removal and Installation"](#).

9.“B” TERMINAL CIRCUIT INSPECTION

Check “B” terminal circuit. Refer to [CHG-13, "Diagnosis Procedure"](#).

Is the inspection result normal?

YES >> Replace generator. Refer to [CHG-28, "Removal and Installation"](#).
NO >> Repair as needed.

10.INSPECTION WITH CHARGE WARNING LAMP (IGNITION SWITCH IS ON)

1. Disconnect generator connector and apply ground to “L” terminal.
2. Turn the ignition switch ON.

Does the charge warning lamp illuminate?

YES >> Replace generator. Refer to [CHG-28, "Removal and Installation"](#).
NO >> GO TO 11.

11.CHECK “L” TERMINAL CIRCUIT (OPEN)

Check “L” terminal circuit (OPEN). Refer to [CHG-14, "Diagnosis Procedure"](#).

>> Repair as needed.

A
B
C
D
E
F
G
H
I
J
K
L
N
O
P

CHG

CHARGING SYSTEM

< SYSTEM DESCRIPTION >

SYSTEM DESCRIPTION

CHARGING SYSTEM

System Diagram

INFOID:000000009465964

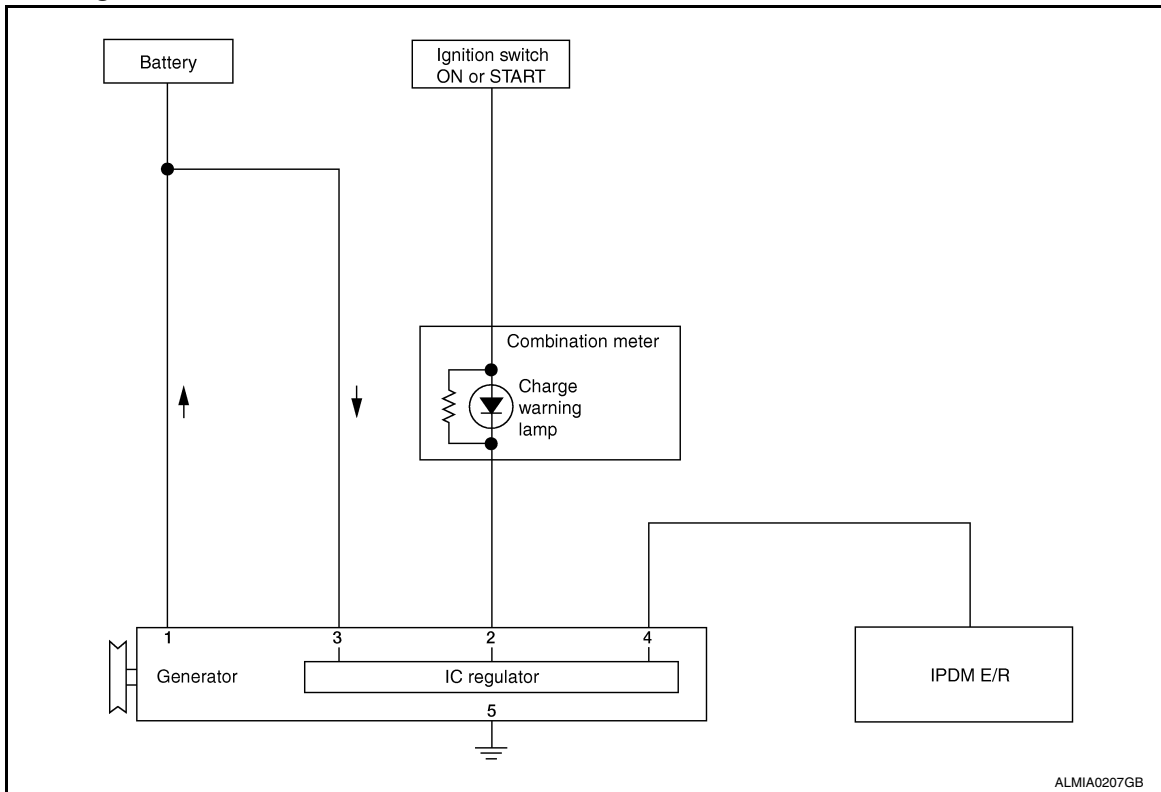

ALMIA0207GB

System Description

INFOID:000000009465965

The generator provides DC voltage to operate the vehicle's electrical system and to keep the battery charged. The voltage output is controlled by the IC regulator.

Component Description

INFOID:000000009465966

Component part		Description
Generator	Terminal "1"	Refer to CHG-13, "Description" .
	Terminal "2"	Refer to CHG-14, "Description" .
	Terminal "3"	Refer to CHG-17, "Description" .
	Terminal "4"	Used for the power generation voltage variable control system. Refer to CHG-9, "System Description" .
Combination meter (Charge warning lamp)		The IC regulator warning function activates to illuminate the charge warning lamp if any of the following symptoms occur while generator is operating: <ul style="list-style-type: none"> Excessive voltage is produced. No voltage is produced.
IPDM E/R		Used for the power generation voltage variable control system. Refer to CHG-9, "System Description" .

POWER GENERATION VOLTAGE VARIABLE CONTROL SYSTEM

< SYSTEM DESCRIPTION >

POWER GENERATION VOLTAGE VARIABLE CONTROL SYSTEM

System Diagram

INFOID:000000009465967

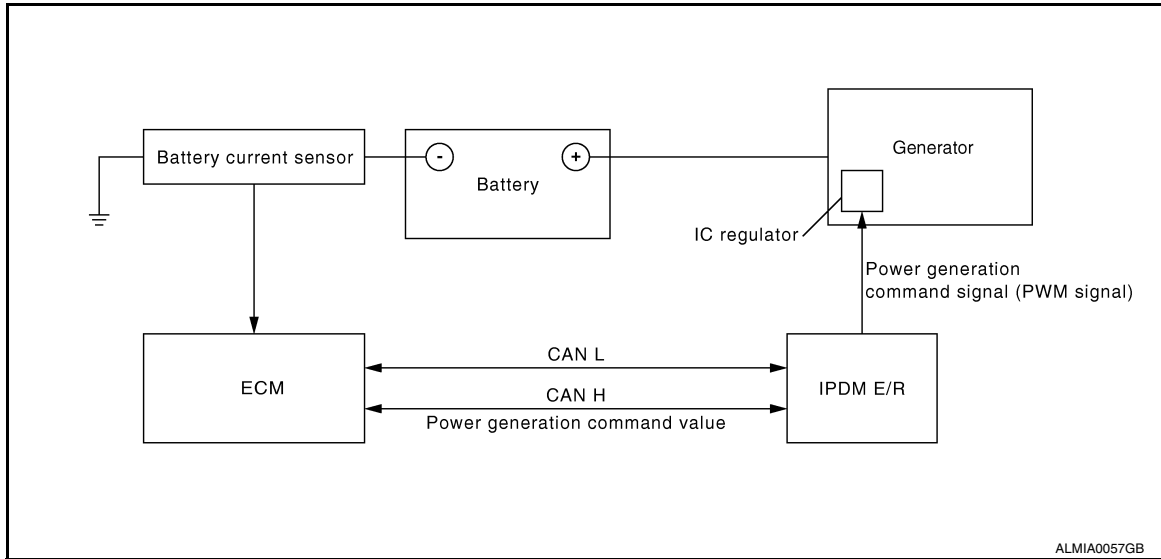

ALMIA0057GB

System Description

INFOID:000000009465968

Power generation variable voltage control system has been adopted. By varying the voltage to the generator, engine load due to power generation of the generator is reduced and fuel consumption is decreased.

NOTE:

When any malfunction is detected in the power generation variable voltage control system, power generation is performed according to the characteristic of the IC regulator in the generator.

Component Description

INFOID:000000009465969

Component part	Description
Battery current sensor	The battery current sensor is installed on the battery cable at the negative terminal. The battery current sensor detects the charging/discharging current of the battery and sends a voltage signal to the ECM according to the current value detected.
ECM	The battery current sensor detects the charging/discharging current of the battery. The ECM judges the battery condition based on this signal. The ECM judges whether to request more output via the power generation voltage variable control according to the battery condition. When performing the power generation voltage variable control, the ECM calculates the target power generation voltage according to the battery condition and sends the calculated value as the power generation command value to the IPDM E/R.
IPDM E/R	The IPDM E/R converts the received power generation command value into a pulse width modulated (PWM) command signal and sends it to the IC regulator.
Generator (IC regulator)	The IC regulator controls the power generation voltage by the target power generation voltage based on the received PWM command signal. When there is no PWM command signal, the generator performs the normal power generation according to the characteristic of the IC regulator.

A
B
C
D
E
F
G
H
I
J
K
L
N
O
P

CHG

CHARGING SYSTEM PRELIMINARY INSPECTION

< DTC/CIRCUIT DIAGNOSIS >

DTC/CIRCUIT DIAGNOSIS

CHARGING SYSTEM PRELIMINARY INSPECTION

Diagnosis Procedure

INFOID:000000009465970

1. CHECK BATTERY TERMINALS CONNECTION

Check if battery terminals are clean and tight.

Is the inspection result normal?

YES >> GO TO 2

NO >> Repair battery terminals connection. Confirm repair by performing complete Charging system test using EXP-800 NI or GR8-1200 NI (if available). Refer to applicable Instruction Manual for proper testing procedures.

2. CHECK FUSE

Check for blown fuse and fusible link.

Unit	Power source (Power supply terminals)	Fuse or Fusible Link
Generator	Battery (terminal 3)	Fuse 29
	Battery (terminal 1)	Fusible Link A
Combination meter	Ignition switch ON (terminal 2)	Fuse 4

Is the inspection result normal?

YES >> GO TO 3

NO >> Be sure to eliminate cause of malfunction before installing new fuse or fusible link.

3. CHECK GENERATOR GROUND TERMINAL CONNECTION

Check if connector E230 terminal 5 (generator ground harness) is clean and tight.

Is the inspection result normal?

YES >> GO TO 4

NO >> Repair connection.

4. CHECK DRIVE BELT TENSION

Check drive belt tension. Refer to [CHG-29, "Inspection"](#).

Is the inspection result normal?

YES >> Inspection End.

NO >> Repair as needed.

POWER GENERATION VOLTAGE VARIABLE CONTROL SYSTEM OPERATION INSPECTION

< DTC/CIRCUIT DIAGNOSIS >

POWER GENERATION VOLTAGE VARIABLE CONTROL SYSTEM OPERATION INSPECTION

Diagnosis Procedure

INFOID:000000009465971

Regarding Wiring Diagram information, refer to [CHG-18, "Wiring Diagram"](#).

CAUTION:

When performing this inspection, always use a charged battery that has completed the battery inspection. (When the charging rate of the battery is low, the response speed of the voltage change will become slow. This can cause an incorrect inspection.)

1. CHECK ECM (CONSULT)

Perform ECM self-diagnosis with CONSULT. Refer to [EC-138, "CONSULT Function"](#).

Self-diagnostic results content

No malfunction detected>> GO TO 2

Malfunction detected>> Check applicable parts, and repair or replace corresponding parts.

2. CHECK OPERATION OF POWER GENERATION VOLTAGE VARIABLE CONTROL SYSTEM

1. Connect CONSULT and start the engine.
2. The selector lever is in "P" or "N" position and all of the electric loads and A/C, etc. are turned OFF.
3. Select "ALTERNATOR DUTY" in "Active Test" of "ENGINE", and then check the value of "BATTERY VOLT" monitor when DUTY value of "ALTERNATOR DUTY" is set to 40.0 %.

"BATTERY VOLT"

2 seconds after setting the DUTY value of "ALTERNATOR DUTY" to 40.0 % : 12 - 13.6 V

4. Check the value of "BATTERY VOLT" monitor when DUTY value of "ALTERNATOR DUTY" is set to 80.0%.

"BATTERY VOLT"

20 seconds after setting the DUTY value of "ALTERNATOR DUTY" to 80.0 % : +0.5 V or more against the value of "BATTERY VOLT" monitor when DUTY value is 40.0 %

Is the measurement value within the specification?

YES >> Inspection End.

NO >> GO TO 3

3. CHECK IPDM E/R (CONSULT)

Perform IPDM E/R self-diagnosis with CONSULT. Refer to [PCS-13, "CONSULT Function \(IPDM E/R\)"](#).

Self-diagnostic results content

No malfunction detected>> GO TO 4

Malfunction detected>> Check applicable parts, and repair or replace corresponding parts.

4. CHECK HARNESS BETWEEN GENERATOR AND IPDM E/R

1. Turn ignition switch OFF.
2. Disconnect generator connector and IPDM E/R connector.

POWER GENERATION VOLTAGE VARIABLE CONTROL SYSTEM OPERATION INSPECTION

< DTC/CIRCUIT DIAGNOSIS >

3. Check continuity between generator harness connector F7 (A) terminal 4 and IPDM E/R harness connector F10 (B) terminal 76.

A		B		Continuity
Connector	Terminal	Connector	Terminal	
F7	4	F10	76	Yes

4. Check continuity between generator harness connector F7 (A) terminal 4 and ground.

A		—	Continuity
Connector	Terminal		
F7	4	Ground	No

Is the inspection result normal?

- YES >> Replace IPDM E/R. Refer to [PCS-35, "Removal and Installation"](#).
 NO >> Repair harness or connector between IPDM E/R and generator.

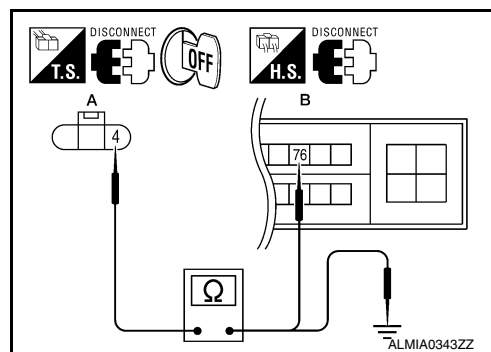

B TERMINAL CIRCUIT

< DTC/CIRCUIT DIAGNOSIS >

B TERMINAL CIRCUIT

Description

INFOID:000000009465972

"B" terminal circuit supplies power to charge the battery and operate the vehicle's electrical system.

Diagnosis Procedure

INFOID:000000009465973

Regarding Wiring Diagram information, refer to [CHG-18, "Wiring Diagram"](#).

1. CHECK "B" TERMINAL CONNECTION

1. Turn ignition switch OFF.
2. Check if "B" terminal is clean and tight.

Is the inspection result normal?

YES >> GO TO 2

NO >> Repair terminal "1" connection. Confirm repair by performing complete Charging system test using EXP-800 NI or GR8-1200 NI (if available). Refer to applicable Instruction Manual for proper testing procedures.

2. CHECK "B" TERMINAL CIRCUIT

Check voltage between generator connector F6 terminal 1 and ground.

1 - ground

Battery voltage

Is the inspection result normal?

YES >> GO TO 3

NO >> Check harness for open between generator and fusible link.

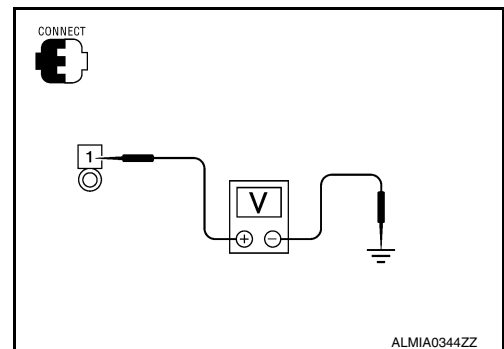

3. CHECK "B" TERMINAL CONNECTION (VOLTAGE DROP TEST)

1. Start engine, then engine running at idle and warm.
2. Check voltage between battery positive terminal and generator connector F6 terminal 1.

1 - B+

Less than 0.2V

Is the inspection result normal?

YES >> "B" terminal circuit is normal. Refer to [CHG-2, "Work Flow \(With EXP-800 NI or GR8-1200 NI\)"](#) or [CHG-5, "Work Flow \(Without EXP-800 NI or GR8-1200 NI\)"](#).

NO >> Check harness between battery and generator for high resistance.

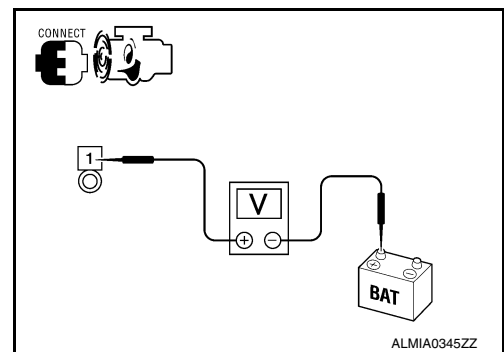

L TERMINAL CIRCUIT (OPEN)

< DTC/CIRCUIT DIAGNOSIS >

L TERMINAL CIRCUIT (OPEN)

Description

INFOID:000000009465974

The "L" terminal circuit controls the charge warning lamp. The charge warning lamp turns ON when the ignition switch is set to ON or START. When the generator is providing sufficient voltage with the engine running, the charge warning lamp turns OFF. If the charge warning lamp illuminates with the engine running, a malfunction is indicated.

Diagnosis Procedure

INFOID:000000009465975

Regarding Wiring Diagram information. Refer to [CHG-18, "Wiring Diagram"](#).

1.CHECK "L" TERMINAL CONNECTION

1. Turn ignition switch OFF.
2. Check if "L" terminal is clean and tight.

Is the inspection result normal?

YES >> GO TO 2.

NO >> Repair "L" terminal connection. Confirm repair by performing complete Charging system test using EXP-800 NI or GR8-1200 NI (if available). Refer to applicable Instruction Manual for proper testing procedures.

2.CHECK "L" TERMINAL CIRCUIT (OPEN)

1. Disconnect the generator connector.
2. Apply ground to generator harness connector terminal.
3. Check condition of the charge warning lamp with the ignition switch in the ON position.

Generator		Ground	Condition	
Connector	Terminal		Ignition switch position	Charge warning lamp
F7	2		ON	Illuminate

Does it illuminate?

YES >> "L" terminal circuit is normal. Refer to [CHG-2, "Work Flow \(With EXP-800 NI or GR8-1200 NI\)"](#) or [CHG-5, "Work Flow \(Without EXP-800 NI or GR8-1200 NI\)"](#).

NO >> GO TO 3.

3.CHECK HARNESS CONTINUITY (OPEN CIRCUIT)

1. Disconnect the battery cable from the negative terminal.
2. Disconnect the combination meter connector.
3. Check continuity between generator harness connector and combination meter harness connector.

Generator		Combination meter		Continuity
Connector	Terminal	Connector	Terminal	
F7	2	M24	25	Yes

Is the inspection result normal?

YES >> GO TO 4.

NO >> Repair or replace the harness or connectors.

4.CHECK HARNESS CONTINUITY (OPEN CIRCUIT)

Check continuity between combination meter harness connector and fuse block (J/B).

Combination meter		Fuse box (J/B)		Continuity
Connector	Terminal	Connector	Terminal	
M24	2	M5	12M	Yes

L TERMINAL CIRCUIT (OPEN)

< DTC/CIRCUIT DIAGNOSIS >

Is the inspection result normal?

YES >> GO TO 5.

NO >> Repair or replace the harness or connectors.

5.CHECK POWER SUPPLY CIRCUIT

1. Connect the battery cable to the negative terminal.
2. Check voltage between combination meter harness connector and ground.

(+)		(-)	Condition	Voltage (Approx.)
Combination meter				
Connector	Terminal			
M24	2	Ground	When the ignition switch is in ON position	Battery voltage

Is the inspection result normal?

YES >> Replace the combination meter. Refer to [MWI-122. "Removal and Installation"](#).

NO >> Repair or replace the harness or connectors.

A
B
C
D
E
F
G
H
I
J
K
L
N
O
P

CHG

L TERMINAL CIRCUIT (SHORT)

< DTC/CIRCUIT DIAGNOSIS >

L TERMINAL CIRCUIT (SHORT)

Description

INFOID:000000009465976

The terminal "L" circuit controls the charge warning lamp. The charge warning lamp turns ON when the ignition switch is set to ON or START. When the generator is providing sufficient voltage with the engine running, the charge warning lamp turns off. If the charge warning lamp illuminates with the engine running, a malfunction is indicated.

Diagnosis Procedure

INFOID:000000009465977

Regarding Wiring Diagram information, refer to [CHG-18, "Wiring Diagram"](#).

1. CHECK "L" TERMINAL CIRCUIT (SHORT)

1. Turn ignition switch OFF.
2. Disconnect generator connector.
3. Turn ignition switch ON.

Does charge warning lamp illuminate?

YES >> GO TO 2.

NO >> Refer to [CHG-2, "Work Flow \(With EXP-800 NI or GR8-1200 NI\)"](#) or [CHG-5, "Work Flow \(Without EXP-800 NI or GR8-1200 NI\)"](#).

2. CHECK HARNESS CONTINUITY (SHORT CIRCUIT)

1. Turn ignition switch OFF.
2. Disconnect the battery cable from the negative terminal.
3. Disconnect combination meter connector.
4. Check continuity between the combination meter harness connector and ground.

Combination meter		Ground	Continuity
Connector	Terminal		
M24	25		No

Is the inspection result normal?

YES >> Replace the combination meter. Refer to [MWI-122, "Removal and Installation"](#).

NO >> Repair or replace the harness or connectors.

S TERMINAL CIRCUIT

< DTC/CIRCUIT DIAGNOSIS >

S TERMINAL CIRCUIT

Description

INFOID:000000009465978

The output voltage of the generator is controlled by the IC voltage regulator at the "S" terminal detecting the input voltage. Terminal "S" circuit detects the battery voltage to adjust the generator output voltage with the IC voltage regulator.

Diagnosis Procedure

INFOID:000000009465979

Regarding Wiring Diagram information, refer to [CHG-18. "Wiring Diagram"](#).

1. CHECK "S" TERMINAL CONNECTION

1. Turn ignition switch OFF.
2. Check if "S" terminal is clean and tight.

Is the inspection result normal?

YES >> GO TO 2.

NO >> Repair "S" terminal connection. Confirm repair by performing complete Charging system test using EXP-800 NI or GR8-1200 NI (if available). Refer to the applicable Instruction Manual for proper testing procedures.

2. CHECK "S" TERMINAL CIRCUIT

Check voltage between generator harness connector and ground.

(+) Generator		(-) Ground	Voltage (Approx.) Battery voltage
Connector	Terminal		
F7	3		

Is the inspection result normal?

YES >> Refer to [CHG-2. "Work Flow \(With EXP-800 NI or GR8-1200 NI\)"](#) or [CHG-5. "Work Flow \(Without EXP-800 NI or GR8-1200 NI\)"](#).

NO >> Check harness for open between generator and fuse.

A
B
C
D
E
F
G
H
I
J
K
L
N
O
P

CHG

CHARGING SYSTEM

< WIRING DIAGRAM >

WIRING DIAGRAM

CHARGING SYSTEM

Wiring Diagram

INFOID:000000009465980

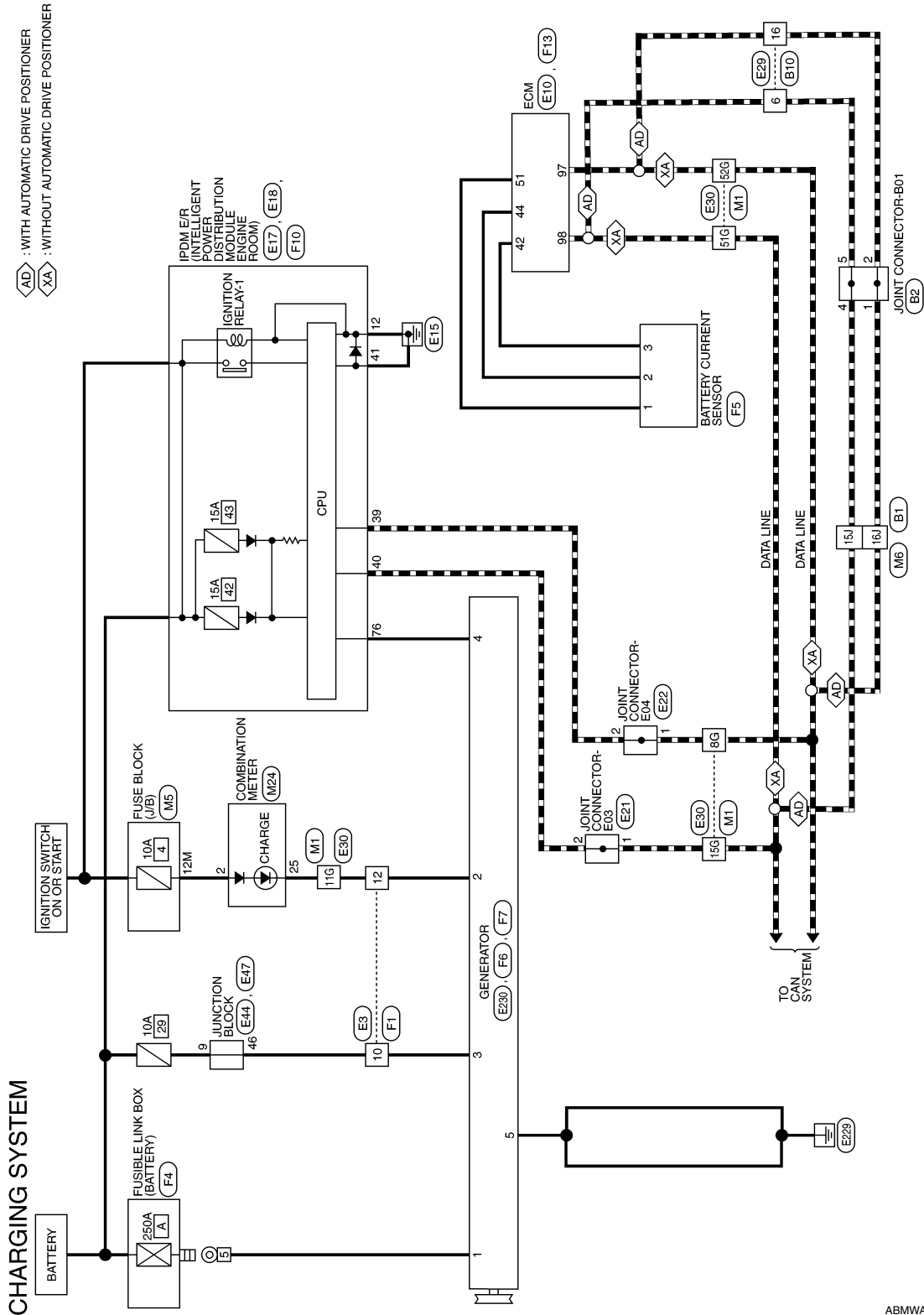

ABMWA2202GB

CHARGING SYSTEM

< WIRING DIAGRAM >

CHARGING SYSTEM CONNECTORS

Connector No.	M1
Connector Name	WIRE TO WIRE
Connector Color	WHITE

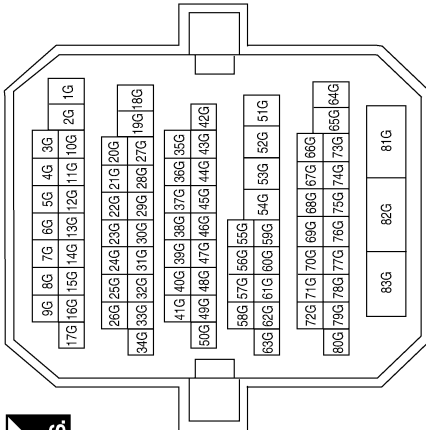

Terminal No.	Color of Wire	Signal Name
8G	P	-
11G	BR	-
15G	L	-
51G	L	-
52G	P	-

Connector No.	M5
Connector Name	FUSE BLOCK (J/B)
Connector Color	WHITE

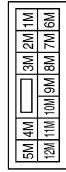

Terminal No.	Color of Wire	Signal Name
12M	O	-

Connector No.	M6
Connector Name	WIRE TO WIRE
Connector Color	WHITE

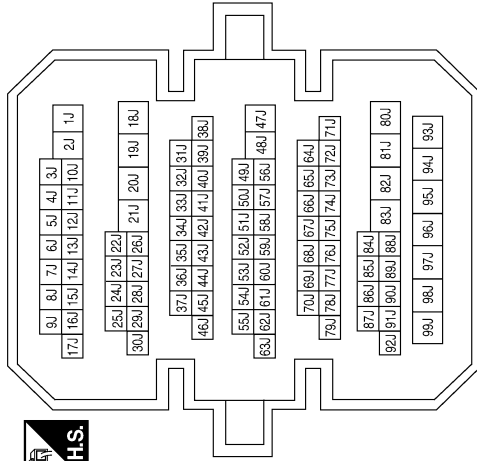

Terminal No.	Color of Wire	Signal Name
15J	L	-
16J	P	-

A
B
C
D
E
F
G
H
I
J
K
L
CHG
N
O
P

CHARGING SYSTEM

< WIRING DIAGRAM >

Connector No.	E10
Connector Name	ECM
Connector Color	BLACK

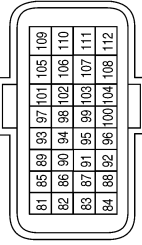

Terminal No.	Color of Wire	Signal Name
97	P	CAN-L
98	L	CAN-H

Connector No.	E3
Connector Name	WIRE TO WIRE
Connector Color	WHITE

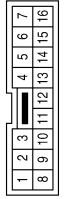

Terminal No.	Color of Wire	Signal Name
10	W	-
12	LG	-

Connector No.	M24
Connector Name	COMBINATION METER
Connector Color	WHITE

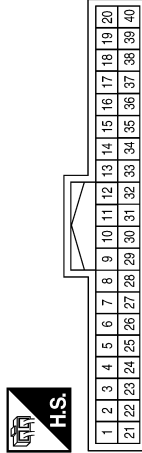

Terminal No.	Color of Wire	Signal Name
2	O	IGN
25	BR	CHG

Connector No.	E21
Connector Name	JOINT CONNECTOR-E03
Connector Color	WHITE



Terminal No.	Color of Wire	Signal Name
1	L	-
2	L	-

Connector No.	E18
Connector Name	IPDM E/R (INTELLIGENT POWER DISTRIBUTION MODULE ENGINE ROOM)
Connector Color	WHITE

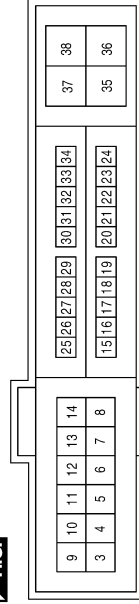

Terminal No.	Color of Wire	Signal Name
12	B	GND (POWER)

Connector No.	E17
Connector Name	IPDM E/R (INTELLIGENT POWER DISTRIBUTION MODULE ENGINE ROOM)
Connector Color	WHITE

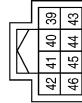

Terminal No.	Color of Wire	Signal Name
39	P	CAN-L
40	L	CAN-H
41	B	GND (SIGNAL)

ABMIA1334GB

CHARGING SYSTEM

< WIRING DIAGRAM >

Connector No.	E22
Connector Name	JOINT CONNECTOR-E04
Connector Color	WHITE

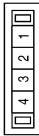

Terminal No.	Color of Wire	Signal Name
1	P	-
2	P	-

Connector No.	E29
Connector Name	WIRE TO WIRE
Connector Color	WHITE

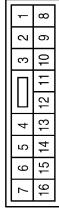

Terminal No.	Color of Wire	Signal Name
6	L	-
16	P	-

Connector No.	E30
Connector Name	WIRE TO WIRE
Connector Color	WHITE

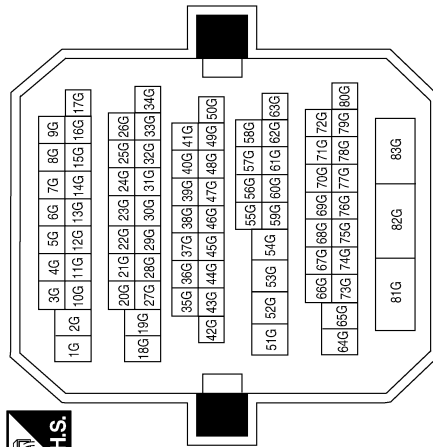

Terminal No.	Color of Wire	Signal Name
8G	P	-
11G	LG	-
15G	L	-
51G	L	-
52G	P	-

Connector No.	E44
Connector Name	JUNCTION BLOCK
Connector Color	BROWN

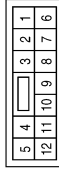

Terminal No.	Color of Wire	Signal Name
9	BR	-

ABMIA1335GB

A
B
C
D
E
F
G
H
I
J
K
L
N
O
P

CHG

CHARGING SYSTEM

< WIRING DIAGRAM >

Connector No.	F1
Connector Name	WIRE TO WIRE
Connector Color	WHITE

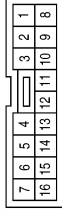

Terminal No.	Color of Wire	Signal Name
10	Y/B	-
12	BR	-

Connector No.	E230
Connector Name	GENERATOR
Connector Color	-



Terminal No.	Color of Wire	Signal Name
5	B	-

Connector No.	E47
Connector Name	JUNCTION BLOCK
Connector Color	WHITE

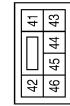

Terminal No.	Color of Wire	Signal Name
46	W	-

Connector No.	F6
Connector Name	GENERATOR
Connector Color	-



Terminal No.	Color of Wire	Signal Name
1	B/R	-

Connector No.	F5
Connector Name	BATTERY CURRENT SENSOR
Connector Color	BLACK



Terminal No.	Color of Wire	Signal Name
1	R/Y	-
2	G/B	-
3	BR	-

Connector No.	F4
Connector Name	FUSIBLE LINK BOX (BATTERY)
Connector Color	-



Terminal No.	Color of Wire	Signal Name
5	B/R	-

ABMIA3925GB

CHARGING SYSTEM

< WIRING DIAGRAM >

Connector No.	F7
Connector Name	GENERATOR
Connector Color	BLACK



Terminal No.	Color of Wire	Signal Name
2	BR	-
3	Y/B	-
4	SB	-

Connector No.	F10
Connector Name	IPDM E/R (INTELLIGENT POWER DISTRIBUTION MODULE ENGINE ROOM)
Connector Color	WHITE

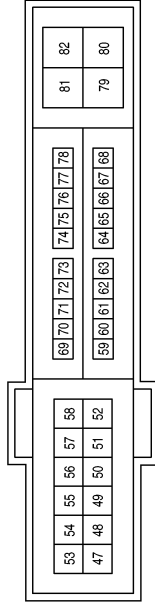

Terminal No.	76	Color of Wire	SB	Signal Name	ALT C
--------------	----	---------------	----	-------------	-------

Connector No.	F13
Connector Name	ECM
Connector Color	BROWN

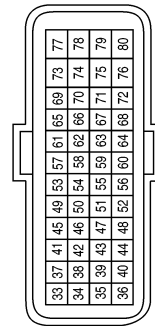

Terminal No.	Color of Wire	Signal Name
42	BR	CURSEN
44	G/B	GND-CURSEN INTPRES 1
51	R/Y	AVCC1-CURSEN, INTPRES 1

Connector No.	B1
Connector Name	WIRE TO WIRE
Connector Color	WHITE

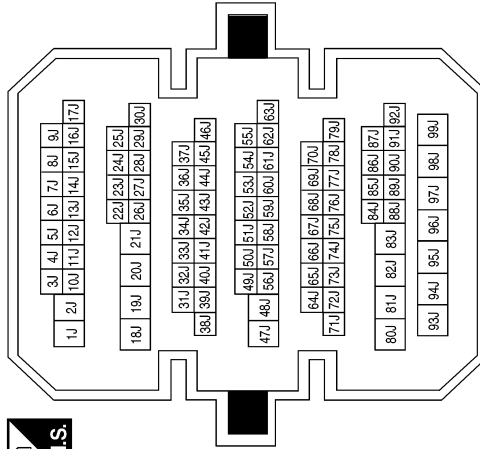

Terminal No.	15J	Color of Wire	L	Signal Name	-
	16J	Color of Wire	P	Signal Name	-

ABMIA5249GB

A
B
C
D
E
F
G
H
I
J
K
L
M
N
O
P

CHG

CHARGING SYSTEM

< WIRING DIAGRAM >

Connector No.	B10
Connector Name	WIRE TO WIRE
Connector Color	WHITE



1	2	3	4	5	6	7		
8	9	10	11	12	13	14	15	16

Terminal No.	Color of Wire	Signal Name
6	L	-
16	P	-

Connector No.	B2
Connector Name	JOINT CONNECTOR-B01
Connector Color	BLACK



6	5	4	3	2	1
---	---	---	---	---	---

Terminal No.	Color of Wire	Signal Name
1	P	-
2	P	-
4	L	-
5	L	-

ABMIA1338GB

CHARGING SYSTEM

< SYMPTOM DIAGNOSIS >

SYMPTOM DIAGNOSIS

CHARGING SYSTEM

Symptom Table

INFOID:000000009465981

Symptom	Reference
Battery discharged	
The charge warning lamp does not illuminate when the ignition switch is set to ON.	
The charge warning lamp does not turn OFF after the engine starts.	Refer to CHG-2, "Work Flow (With EXP-800 NI or GR8-1200 NI)" or CHG-5, "Work Flow (Without EXP-800 NI or GR8-1200 NI)" .
The charging warning lamp turns ON when increasing the engine speed.	

A

B

C

D

E

F

G

H

I

J

K

L

CHG

N

O

P

PRECAUTIONS

< PRECAUTION >

PRECAUTION

PRECAUTIONS

Precaution for Supplemental Restraint System (SRS) "AIR BAG" and "SEAT BELT PRE-TENSIONER"

INFOID:000000009465982

The Supplemental Restraint System such as "AIR BAG" and "SEAT BELT PRE-TENSIONER", used along with a front seat belt, helps to reduce the risk or severity of injury to the driver and front passenger for certain types of collision. This system includes seat belt switch inputs and dual stage front air bag modules. The SRS system uses the seat belt switches to determine the front air bag deployment, and may only deploy one front air bag, depending on the severity of a collision and whether the front occupants are belted or unbelted. Information necessary to service the system safely is included in the SR and SB section of this Service Manual.

WARNING:

- To avoid rendering the SRS inoperative, which could increase the risk of personal injury or death in the event of a collision which would result in air bag inflation, all maintenance must be performed by an authorized NISSAN/INFINITI dealer.
- Improper maintenance, including incorrect removal and installation of the SRS, can lead to personal injury caused by unintentional activation of the system. For removal of Spiral Cable and Air Bag Module, see the SR section.
- Do not use electrical test equipment on any circuit related to the SRS unless instructed to in this Service Manual. SRS wiring harnesses can be identified by yellow and/or orange harnesses or harness connectors.

PRECAUTIONS WHEN USING POWER TOOLS (AIR OR ELECTRIC) AND HAMMERS

WARNING:

- When working near the Airbag Diagnosis Sensor Unit or other Airbag System sensors with the Ignition ON or engine running, DO NOT use air or electric power tools or strike near the sensor(s) with a hammer. Heavy vibration could activate the sensor(s) and deploy the air bag(s), possibly causing serious injury.
- When using air or electric power tools or hammers, always switch the Ignition OFF, disconnect the battery, and wait at least 3 minutes before performing any service.

Precaution for Power Generation Voltage Variable Control System

INFOID:000000009465983

CAUTION:

For this model, the battery current sensor that is installed to the battery cable at the negative terminal measures the charging/discharging current of the battery, and performs various controls. If the electrical component or the ground wire is connected directly to the battery terminal, the current other than that being measured with the battery current sensor is charging to or discharging from the battery. This condition causes the malfunction of the control, and then the battery discharge may occur. Do not connect the electrical component or the ground wire directly to the battery terminal.

PREPARATION

< PREPARATION >

PREPARATION

PREPARATION

Special Service Tool

INFOID:000000009465984

The actual shapes of the tools may differ from those illustrated here.

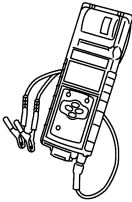
Tool number (TechMate No.) Tool name	Description
<p>— (—) Model GR8-1200 NI Multitasking battery and electrical diagnostic station</p>  <p style="text-align: right;">AWI1A1239ZZ</p>	<p>Tests batteries, starting and charging systems and charges batteries. For operating instructions, refer to diagnostic station instruction manual.</p>
<p>— (—) Model EXP-800 NI Battery and electrical diagnostic analyzer</p>  <p style="text-align: right;">JSMIA0806ZZ</p>	<p>Tests batteries and charging systems. For operating instructions, refer to diagnostic analyzer instruction manual.</p>

Commercial Service Tool

INFOID:000000009465985

Tool name	Description
<p>Power tool</p>  <p style="text-align: right;">PIIB1407E</p>	<p>Loosening nuts, screws and bolts</p>

A
B
C
D
E
F
G
H
I
J
K
L

CHG

GENERATOR

< REMOVAL AND INSTALLATION >

REMOVAL AND INSTALLATION

GENERATOR

Exploded View

INFOID:000000009465986

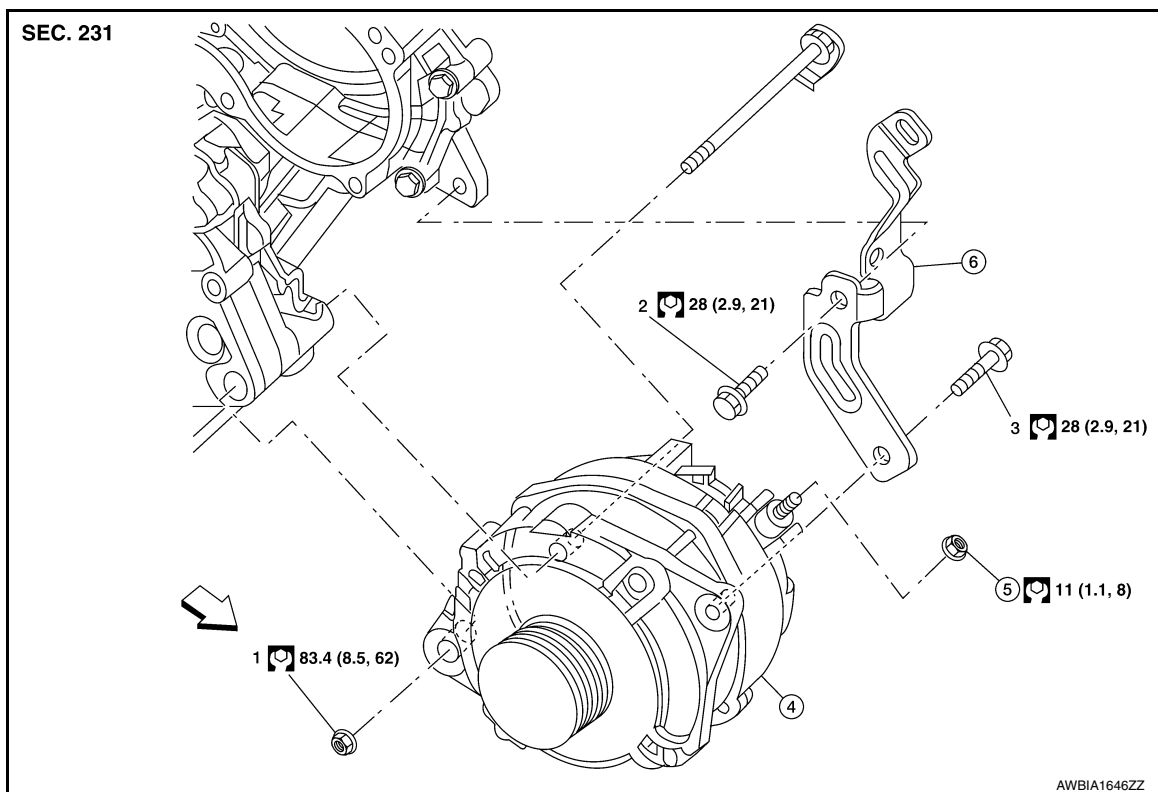

1 - 3 Tightening order

6. Generator bracket

4. Generator

← Front

5. B terminal nut

Removal and Installation

INFOID:000000009465987

REMOVAL

1. Remove hoodledge covers (LH/RH).
2. Remove cooling fan assembly. Refer to [CO-16. "Removal and Installation"](#).
3. Remove the A/C compressor. Refer to [HA-37. "Removal and Installation for Compressor"](#).
4. Remove A/C idler pulley [EM-15. "Removal and Installation of Drive Belt Auto-tensioner"](#).
5. Disconnect the oil pressure switch [EM-36. "Exploded View"](#).
6. Disconnect the generator harness connectors.
7. Remove the generator bolt and nuts, using power tools.
8. Remove generator bracket.
9. Slide the generator out and remove.

INSTALLATION

Installation is in the reverse order of removal. Refer to [CHG-28. "Exploded View"](#)

- Temporarily tighten bolts and nut, then finish tightening in the specified numerical order.

CAUTION:

Be sure to tighten "B" terminal nut carefully.

- Install generator and check tension of belt. Refer to [EM-14. "Checking Drive Belts"](#).
- For this model, the power generation voltage variable control system that controls the power generation voltage of the generator has been adopted. Therefore, the power generation voltage variable control system

GENERATOR

< REMOVAL AND INSTALLATION >

operation inspection should be performed after replacing the generator, and then make sure that the system operates normally. Refer to [CHG-11, "Diagnosis Procedure"](#).

Inspection

INFOID:000000009465988

GENERATOR PULLEY INSPECTION

Perform the following.

- Make sure that generator pulley does not rattle.
- Make sure that generator pulley nut is tight.

NOTE:

Replace the generator as an assembly if necessary.

A
B
C
D
E
F
G
H
I
J
K
L

CHG

N
O
P

SERVICE DATA AND SPECIFICATIONS (SDS)

< SERVICE DATA AND SPECIFICATIONS (SDS)

SERVICE DATA AND SPECIFICATIONS (SDS)

SERVICE DATA AND SPECIFICATIONS (SDS)

Generator

INFOID:000000009465989

Application	VQ35DE
Type*	A003TJ3691ZC
	Mitsubishi
Nominal rating	12V-130A
Ground polarity	Negative
Minimum revolution under no-load	1,000 rpm
Hot output current (when 13.5 volts are applied)	More than 66A/1,500 rpm More than 108A/2,500 rpm More than 124A/5,000 rpm
Regulated output voltage	14.1 - 14.7V @ 20°C (68°F)
Adjustment range of power generation voltage variable control	11.4 - 15.6 V

*: Always check with the Parts Department for the latest parts information